



# eFAST panic exit devices

Motorised rim panic exit device  
for fire doors





# Keeping them safe is our priority

CISA was established in Florence in 1926 and is a leader in the locking systems and access control sector. Today its products are distributed in more than 70 countries and over the past 10 years it has registered more than 70 patents. Since 2013 it has been co-founder and strategic brand of the international group Allegion, listed on the New York Stock Exchange, which has brought together some of the leading global brands in the security technology sector.





We believe the best solutions take shape by listening carefully to our clients and building relationships with them which enable us to make their environments a safer place, implementing new, original, practical and flexible solutions for innovative security systems.

Through our security managers, we identify the specific needs of every context and propose a package of products, working hand-in-hand with you to design and create the best security system possible.

CISA is the Solution.

## Education



## Residential



## Commercial



## Healthcare



## Hospitality







# We examine needs and design solutions

**Applications for panic exit solutions.**

## Education

Ensuring safety in schools is a complex business, especially when it involves young kids. CISA offers a range of features to meet the needs of educational facilities: single key systems with controlled key duplication to make access management easier throughout the buildings, entrances with assisted opening, gates and emergency exits controlled to prevent unauthorised use and to keep pupils, teachers and school equipment safe and sound.



## Commercial

We develop reliable access control solutions for commercial and professional environments.

We offer customised security systems for each of these environments and for the people who work there, designed to prevent forced entry while still allowing personalised access management.



# Healthcare

Healthcare facilities are complex structures which operate 24/7 and patient safety must be guaranteed while managing access of visitors and medical staff alike.

CISA offers keys for hierarchical access with controlled duplication, doors which are easy to open and risk-free when closing, systems to monitor entry and panic exit solutions.



# Hospitality

Hotels and community buildings are subject to heavy human traffic with a large number of people coming and going at all times, so they need flexible yet safe security systems.

CISA solutions control access in real time with easy-to-use management software designed to keep guests' belongings safe, which is suitable for small hotels too, and security systems which are efficient and blend in seamlessly with their surroundings.







# Motorised panic exit solution

CISA eFAST is a panic exit device with an electrically powered opening mechanism. Different access systems can be installed such as a key pad or a card reader, to increase the performance of emergency exit doors exponentially and transform them into effective "smart" entrances.







# eFAST

## 1. PANIC EXIT DEVICE

It can be easily installed on all types of doors and is available in a variety of finishes.



## 2. ANTIBACTERIAL

Protection is achieved thanks to an antibacterial powder coating which prevents the spread of microorganisms.



## 3. PAIR OF LATCHBOLTS

Additional locking points can be installed with a quick-lock system.

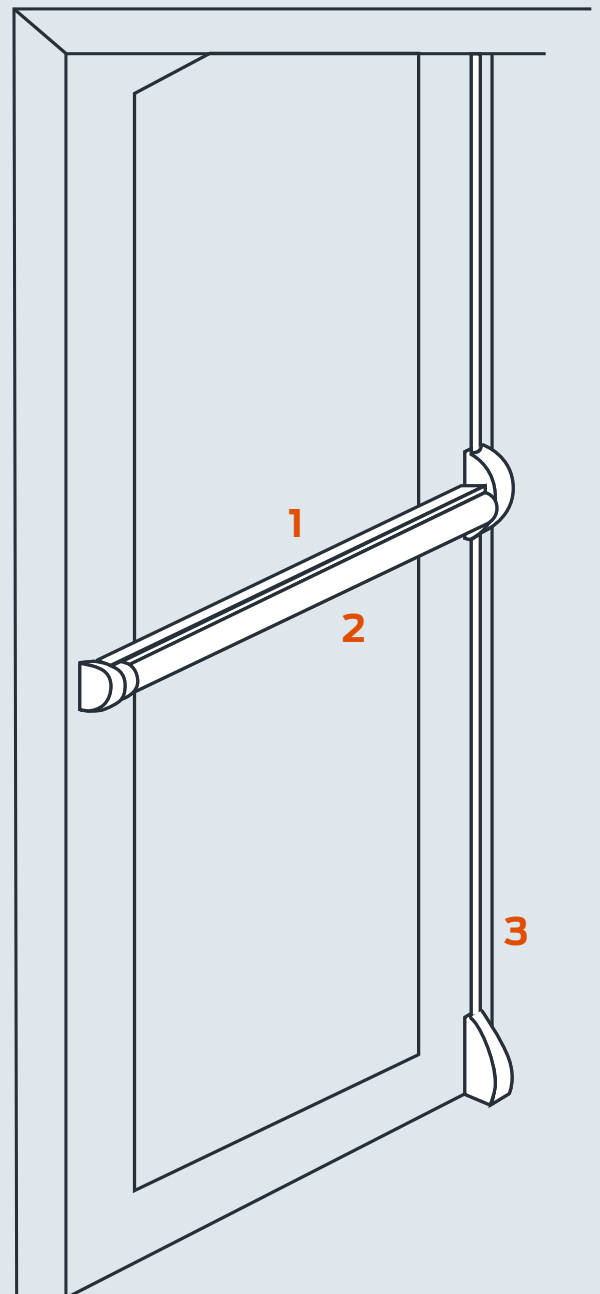

INSIDE



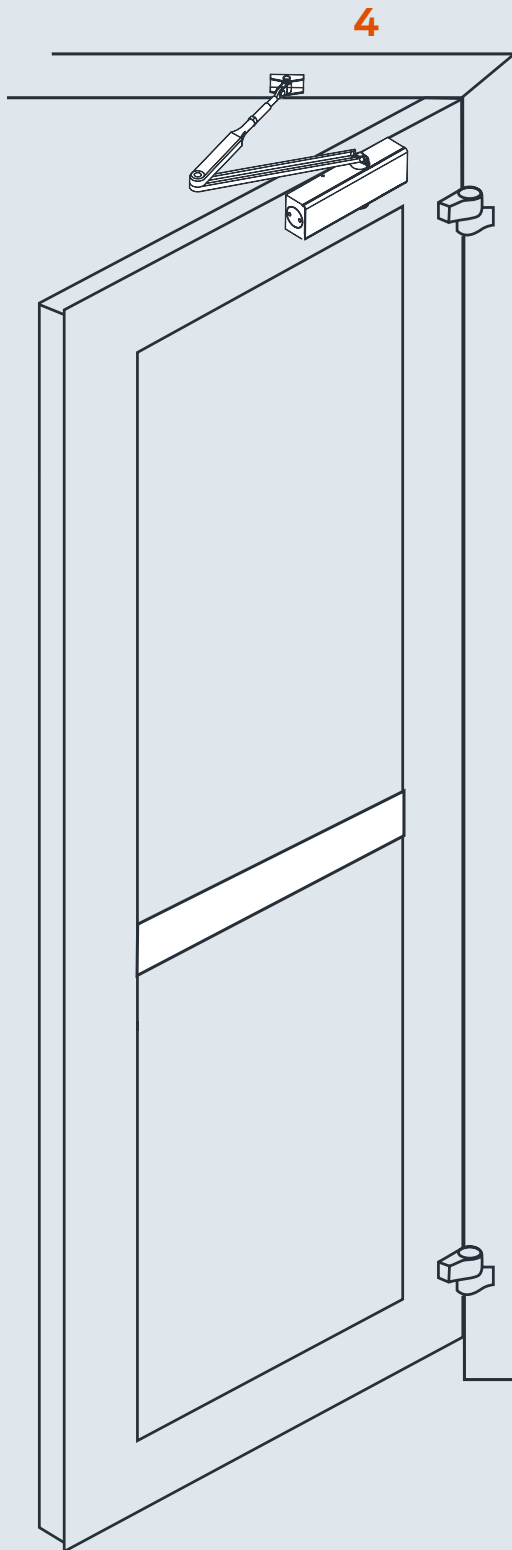

OUTSIDE

#### 4. DOOR CLOSERS

They are designed to facilitate the initial pushing stage, making it easier to open the door. They are available in a number of versions and can be installed on different types of doors.



#### 5



#### 5. CISA KEY PAD

Cabled key pad to control each access. The motorised panic exit device can be integrated into an existing access control system.







# eFAST



CISA eFAST motorised panic exit devices can increase security levels and performance wherever they are installed: schools and universities, offices and companies, hotels and B&Bs, hospitals.

CISA eFAST motorised panic exit device delivers innovative methods for opening doors and managing access control establishing hierarchical rights and timings.

The motorised solution can be installed to upgrade a mechanical version, enabling you to control access from the outside. It can be connected with existing access control systems. The key pad allow efficient management of staff and widespread entry control.





On request:

- Cabled key pad to control each access series 06525





# Benefits and features

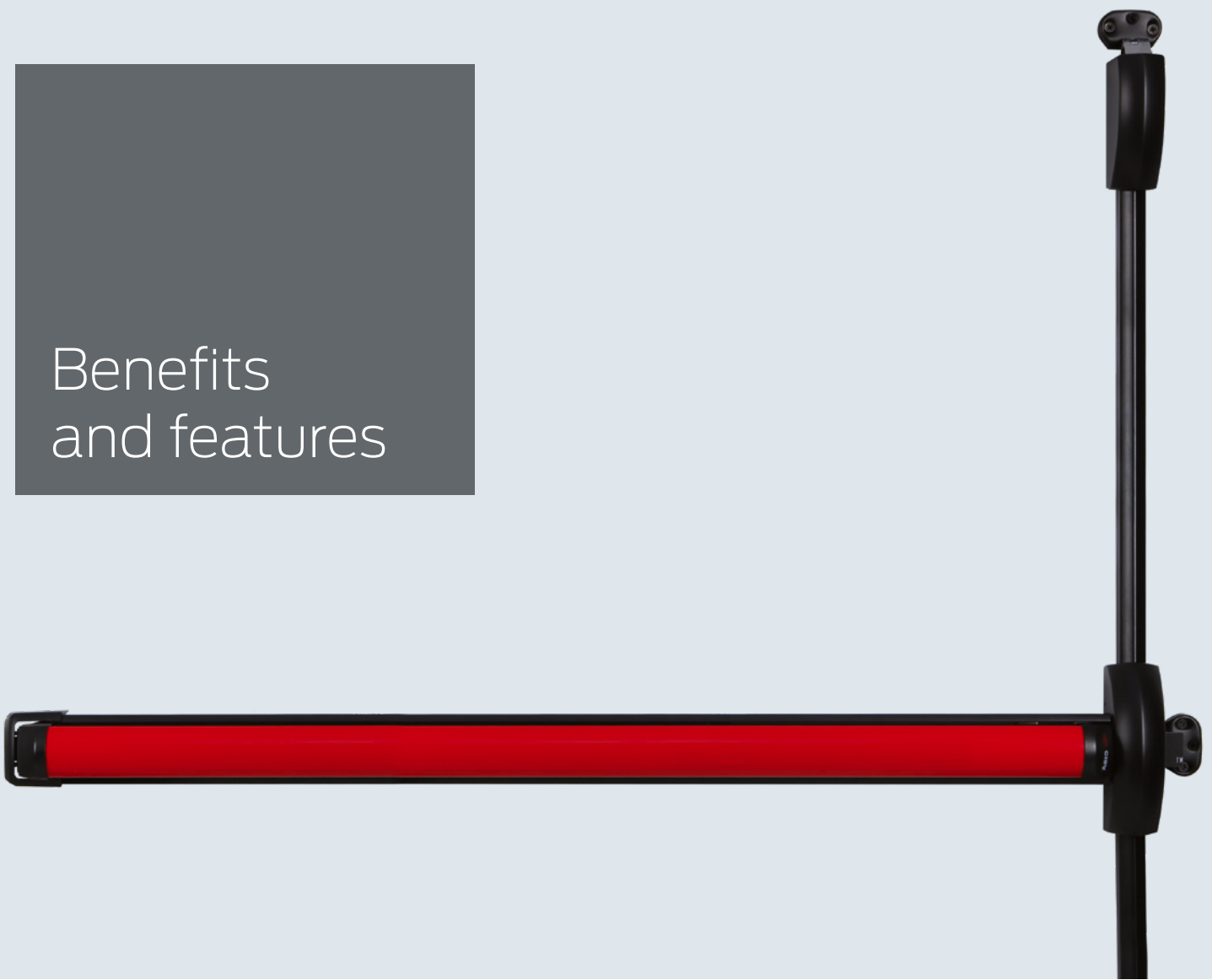

## ANTIBACTERIAL PROTECTION

CISA FAST PLUS protects, thanks to an antibacterial powder coating which prevents the spread of dangerous microorganisms and the growth of fungi and bacteria.



## MAXIMUM SECURITY

Thanks to the system which blocks the door in three different points, the risk of forced entry is reduced and closing becomes smooth and silent, the ideal solution for locations with heavy human traffic.

## CERTIFICATIONS AND MARKINGS

The materials used and the technical solutions adopted are in compliance with the strictest regulatory requirements. This has enabled CISA to obtain the CE Marking in compliance with the Construction Products Regulation No. 305/2011.

The product is also in compliance with the Electromagnetic Compatibility (EMC) Directive 2014/30/EU for residential and industrial applications.

## OPERATION

The panic exit device has the same features as the mechanical version, in compliance with EN1125, but offers an additional electronic opening function.



Panic exit devices series 59351



Pair of latchbolts for lateral locking point cod. 1 07063 51 0



Pair of latchbolts for top/bottom locking points cod. 1 07063 61 0

## FEATURES

- CE-marked
- Non-handed
- Panic exit device can be shortened to 600 mm
- Rim version
- Can be integrated into an existing access control system.  
Can also be controlled by a button
- Power supply 12-20V AC, 12-24V DC
- Max. current absorption 1.5A
- Current absorption in standby: 5mA
- Length of connecting cable 4 m
- Operating temperature from -10 to +50°C
- Power supply not supplied. A 12V AC transformer is available on request
- Opening acoustic alarm
- Timed latch withdrawal after opening, adjustable from 3 to 30 seconds
- Possibility of installing an electric hold open device

**Power supply features:** 12/24 V AC DC 30W



# Finishes and accessories codes

## PANIC EXIT DEVICES FINISHES

Standard

**Black casing, red bar**

On request

**White**  
**RAL 9010**

Fin. 45

**Grey**  
**RAL 9006**

Fin. 97

**Stainless**  
**steel grey**

Fin. B9

**PVD**  
**Satin finished**  
**stainless**  
**steel**

Fin. C2

## KEY PAD FINISHES

Standard

**Shiny black**

On request

**Satin finished**  
**chrome**

Fin. B1



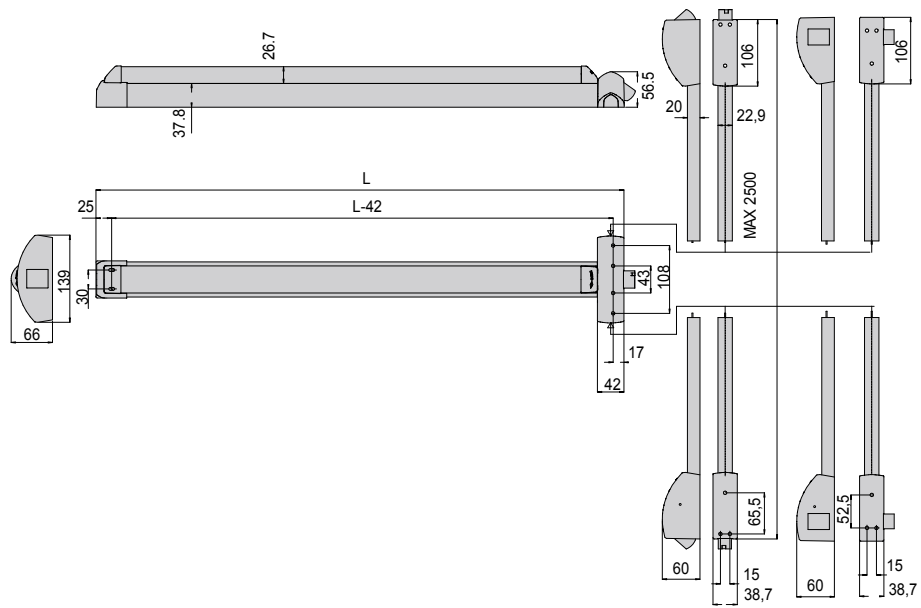

## CISA eFAST

### ITEM

<b>1 59851 09 0</b>	L 1.300	Motorised modular panic exit device Also available for fire doors (spec. FR)
<b>1 59851 10 0</b>	L 1.200	
<b>1 59851 11 0</b>	L 840	

### ITEM

### ON REQUEST

<b>1 07063 51 0</b>	Pair of latchbolts for lateral locking point
<b>1 07063 61 0</b>	Pair of latchbolts for top/bottom locking points

### ITEM

### ACCESSORIES

<b>1 06515 00 0</b>	Concealed cable guard
---------------------	-----------------------

### ITEM

<b>1 06515 15 0</b>	Internal cable guard with spring
---------------------	----------------------------------

### ITEM

<b>1 06515 21 0</b>	L 600	External cable guard with spring
<b>1 06515 20 0</b>	L 300	External cable guard with spring

### ITEM

### FINISH

<b>1 06525 77 0</b>	Shiny black
<b>1 06525 77 0 B1</b>	Satin-finished chrome

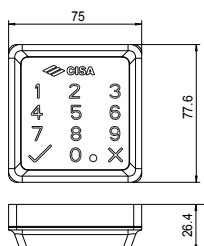
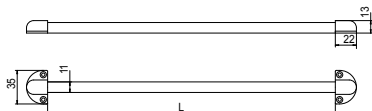
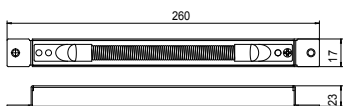
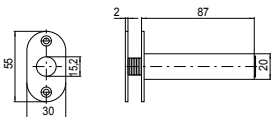
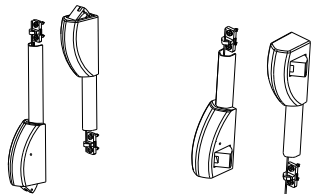
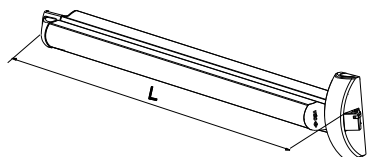





## About Allegion

Allegion (NYSE: ALLE) is a global pioneer in seamless access, with leading brands like CISA®, Interflex®, LCN®, Schlage®, SimonsVoss® and Von Duprin®. Focusing on security around the door and adjacent areas, Allegion secures people and assets with a range of solutions for homes, businesses, schools and institutions.





For more, visit [allegion.com](http://allegion.com).



 CISA SpA  
Via Oberdan 42  
48018 Faenza (RA) Italy

 Ph. +39 0546 677111  
Fax +39 0546 677150

 Customer Service and Technical Support  
+39 0546 188 0070

    [cisa.com](http://cisa.com)  
[cisa.sales@allegion.com](mailto:cisa.sales@allegion.com)